

# REMOTE TOROIDAL TRANSFORMERS

SLI offers toroidal magnetic transformers for use with our low voltage systems. Toroidal magnetic transformers are a premium type of magnetic transformer that are superior to a conventional laminated core transformer. They operate cooler, are more efficient, have a greater life expectancy, produce less stray magnetic fields, and are quieter than conventional core and coil transformers.

Because of their superior efficiency, toroidal transformers are more susceptible to in-rush current. When a circuit is loaded near to its current carrying capacity, the in-rush current may open the circuit breaker when the power is turned on. To avoid this inconvenience, it is recommended that when using toroidal transformers, a HACR breaker be installed in the panel supplying power to the fixture. HACR breakers have a built in time delay circuit that enables them to stay closed (on) when there is in-rush current.

Our products contain a high density of lamps per linear foot and any harmonic resonance produced by the transformer will result in the filaments audibly vibrating. Dimming will intensify the noise problem, so whenever dimmers are used we recommend that a choke or lamp debuzzing coil be specified as part of the dimming system.

Our transformers feature:

- Epoxy encapsulation for quiet, cool operation.
- Powder painted cases for maximum protection.
- Thermostat protection of the primary windings.
- Individual 25 amp circuit breaker protection for the secondary circuits.
- An easy opening case with knock-outs for hardwiring.
- Secondary Multi-Tap (12v-13v-14v-15v) to compensate for long-run voltage losses.
- All units: 120 volts, 60Hz input, 12v, 13v, 14v, 15v output.
- All units are UL listed to U.S. and Canadian safety standards.

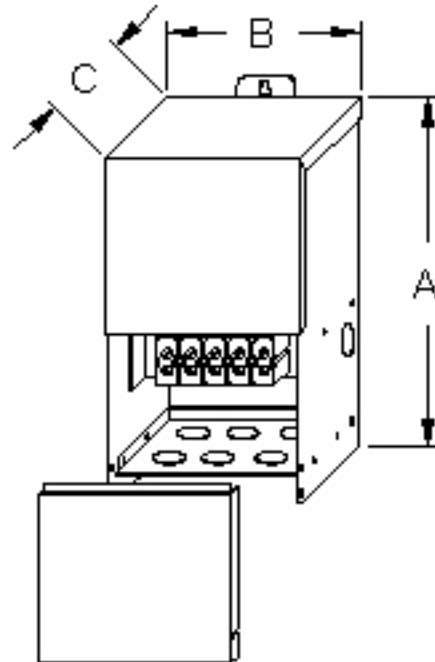

Part Number	Wattage	Circuits	"A"	"B"	"C"	Weight
20300-T	300	1	9 1/2"	5 1/2"	4 3/4"	9 lbs
20600-T	600	2	11"	6"	5 1/2"	15 lbs
20750-T	750	3	11"	6"	5 1/2"	20 lbs

Also available in 220 or 277 volts, 50/60 Hz input and 24v secondary output. Consult factory for details.