

Multilamp halogen low voltage recessed linear wall grazer with nominal 2" (50mm) wide aperture, flangeless housing and re-gressed borosilicate supertex spread lens.

TYPE: _____

JOB: _____

SPECIFIER: _____

SPECIFICATIONS

HOUSING - Extruded aluminum with seamless welded and ground end plates and perforated metal plaster flange.

MOUNTING - Recessed in sheetrock ceiling.

ELECTRICAL - Fixture comes with 10' (3M) whip of 10 Ga. wire for connection to remote transformer. Transformer should be sized for the run length and ordered separately.

LAMP - ALR-12 (GBD), MR-11 (FSS) narrow spot 20w max. supplied by others.

LABELS - UL, C-UL

SOCKET - Precision die formed aluminum socket plate. G4/G6 ceramic socket or nickel plated steel double contact bayonet base with stainless steel spring for optimum contact. High temperature lead wires.

LENS - Supertex borosilicate glass. Others available consult factory

FINISH - Powder paint on all surfaces available in black white or RAL colors as standard. Consult factory for custom finishes.

APPLICATIONS

Narrow profile wall grazer used in low to medium ceiling heights to highlight the texture in surfaces such as stucco or brick, illuminate flat surfaces such as venetian plaster, fabric or wood, or light specular surfaces such as polished stone or stainless

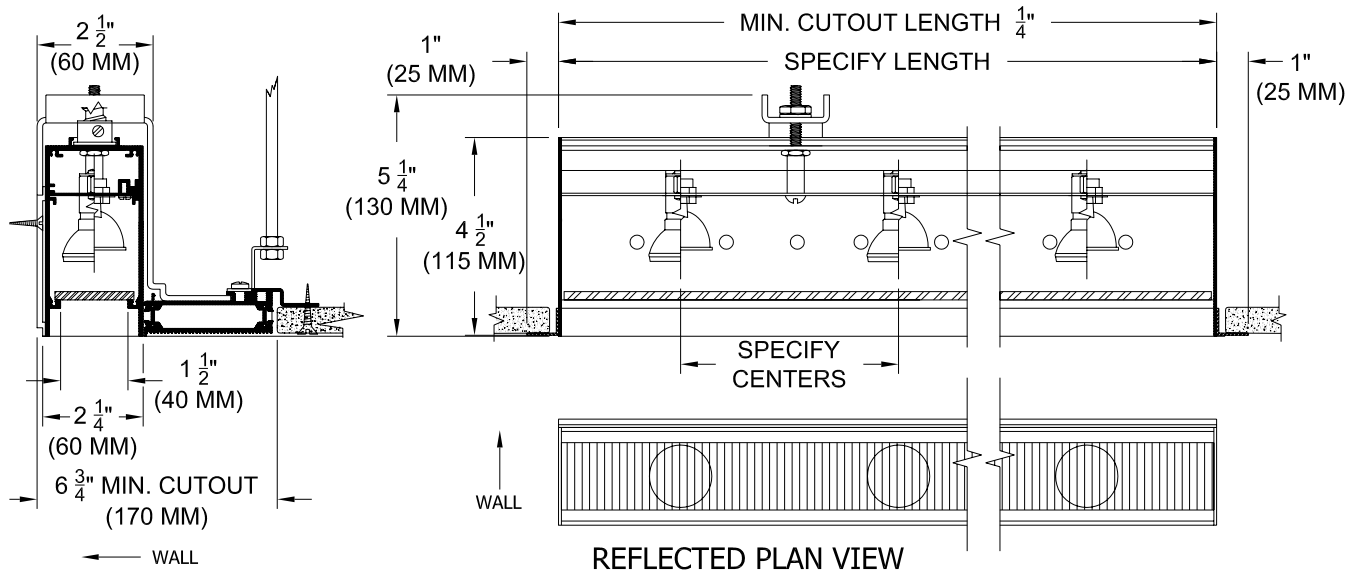

ORDERING INFORMATION

HOUSING	LAMP SPACING	LENGTH	FINISH	APERTURE LENS
805-__-PH-RX				
Flangeless housing ALR = ALR 12 lamp MR = MR 11 lamp	4 = 4" 100 = 100mm 6 = 6" 150 = 150mm or custom spacing	Specify exact length	WHT = White BLK = Black PXX = SLI Color XXXX = RAL # CST = Custom	91A = Solite 92A = Supertex 93A = Sandblasted 95A = Full Prismatic

This information is provided as a specification aid. A submittal will be prepared by the manufacturer for approval prior to fabricating this product.



SPECIALTY LIGHTING INDUSTRIES, INC.

NOTE: These specifications subject to change without notice.

www.specialtylightingindustries.com

1306 DORIS AVENUE, OCEAN, NJ 07712 USA 800.462.7812 732.517.0800 FAX 732.517.0971 © 02/10