

Multi-lamp, solid state light engine, recessed linear wall grazer with flangeless housing, nominal 1.5" wide aperture and acrylic lens.

TYPE: \_\_\_\_\_

JOB: \_\_\_\_\_

SPECIFIER: \_\_\_\_\_

**SPECIFICATIONS**

**HOUSING** - Extruded aluminum with ultrim plaster frame.

**SOCKET** - Circuit board mounted to extruded aluminum heatsink. Inline connectors allow removal and replacement.

**MOUNTING** - Recessed in sheetrock ceiling.

**LENS** - Acrylic diffusing lens Others available consult factory.

**ELECTRICAL** - Integral electronic 12v, 500ma 0-10v dimmable driver. Remote 12VAC transformer should be sized for the run length and ordered separately.

**TRIM** - Lens frame integral to housing.

**LAMP** - 2 watt 3000K LED 2" o.c. supplied with fixture.

**FINISH** - Powder paint on all surfaces in black and white as standard. Additional colors and RAL palette available. Consult factory for custom finishes.

**LABELS** - UL, CUL, Damp location Listings pending

**APPLICATIONS**

Narrow profile wall grazer used in low ceiling heights to highlight the texture in surfaces such as stucco or brick, illuminate flat surfaces such as venetian plaster, fabric or wood, or specular surfaces such as polished stone or stainless steel.

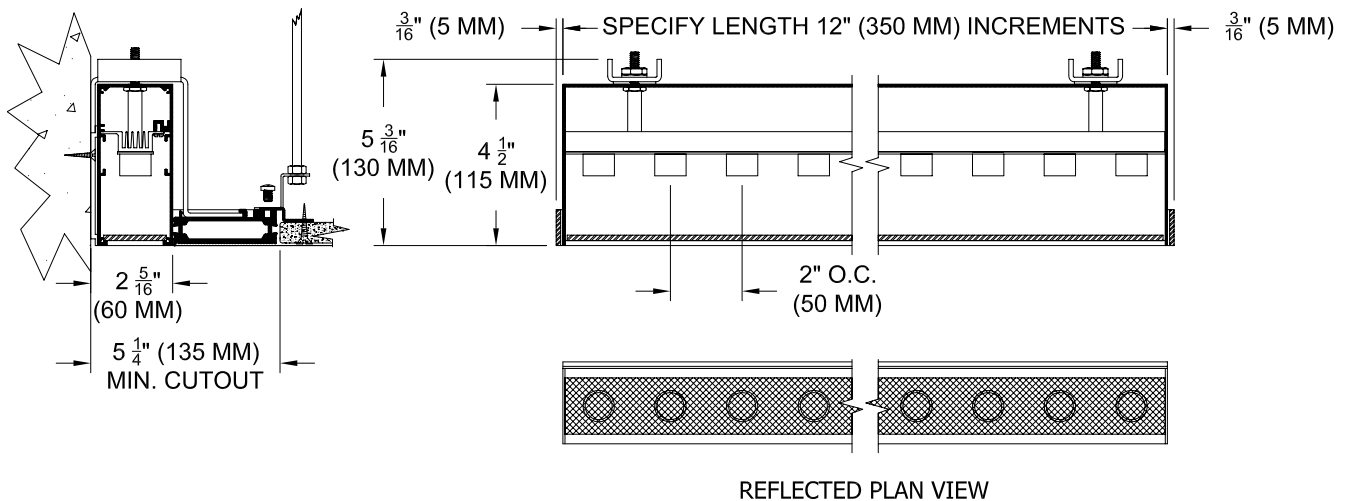

**ORDERING INFORMATION**

HOUSING	TRANSFORMER	LENGTH	FINISH	APERTURE LENS
801-LED-PH				
Flangeless Housing	RX = Remote	Specify length to nearest foot	WHT = White BLK = Black PXX = SLI Color XXXX = RAL # CST = Custom	79A = Veiling Acrylic 91A = Solite

This information is provided as a specification aid. A submittal will be prepared by the manufacturer for approval prior to fabricating this product.



**SPECIALTY LIGHTING INDUSTRIES, INC.**

NOTE: These specifications subject to change without notice.

[www.specialtylightingindustries.com](http://www.specialtylightingindustries.com)

1306 DORIS AVENUE, OCEAN, NJ 07712 USA 800.462.7812 732.517.0800 FAX 732.517.0971 © 03/09