

**SERIES #1240 - RECTANGULAR APERTURE ACCENT/WASHER 1240AW-1MR16/1MR16MH-WH-ZT**

Twin lamp, low-voltage halogen and metal halide, recessed combination wall washer and accent light with nominal 4"x8" rectangular 2 cell aperture and flangeless trim.

**TYPE:** \_\_\_\_\_

**JOB:** \_\_\_\_\_

**SPECIFIER:** \_\_\_\_\_

**SPECIFICATIONS**

**HOUSING** - Precision die-formed heavy gauge aluminum with extruded ceiling collar.

**MOUNTING** - Recessed in millwork or stone ceiling.

**ELECTRICAL** - Integral electronic ballast and dimmable electronic transformer. 120v primary lead, (220v, 240v, 277v available). External thermoprotector.

**LAMP** - GE MR16 CMH 20w  
MR-16 50w max. supplied by others.

**LABELS** - UL, C-UL, Damp Location

**SOCKET** - Precision die-formed aluminum socket plate and one adjustable aluminum yoke and CNC machined lampholder assembly. GX10 and G4/G6 ceramic sockets with high temperature lead wires.

**LENS** - Supertex borosilicate spread lens, hinged for relamping. Optional lens on accent light cell.

**TRIM** - Flangeless, two piece die-cast aluminum pyramidal shield.

**FINISH** - Black powder paint housing. Aperture trim available in black white or RAL colors as standard. Consult factory for custom finishes.

**APPLICATIONS**

Wallwashing and accent lighting in low to medium ceiling heights typically found in commercial and retail applications. Suitable for new construction.

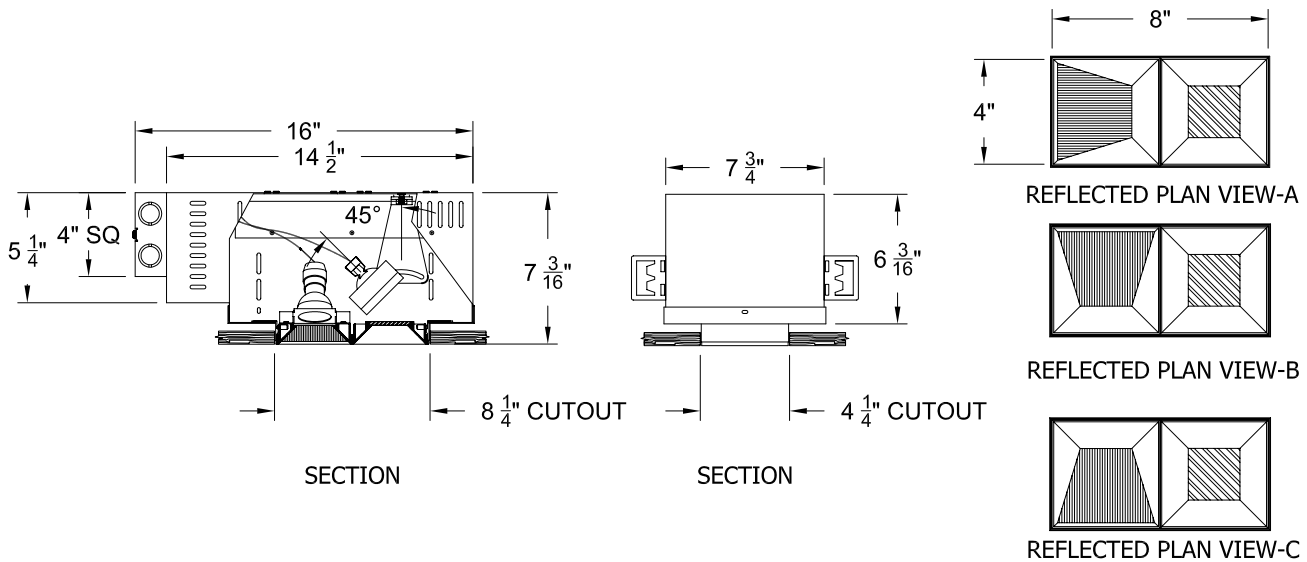

**ORDERING INFORMATION**

HOUSING	TRIM	VOLTAGE	LENS HOLDER	LAMP LENS	TRIM FINISH	APERTURE LENS
1240AW_MR16/MR16MH-WH	ZT					
Wood housing AWA = Side WW AWB = Right WW AWC = Left WW	ZT = Zero Trim	120 220 240 277	CL= Conical FL = Flat	91S = Solite 92S = Supertex 93S = Sandblasted 94S = Clear 95S = Full Prismatic	P14 = Matte White BLK = Black XXXX = RAL # CST = Custom (supply chip)	91A = Solite 92A = Supertex 93A = Sandblasted 94A = Clear 95A = Full Prismatic



**SPECIALTY LIGHTING INDUSTRIES, INC.**

NOTE: These specifications subject to change without notice.

[www.specialtylightingindustries.com](http://www.specialtylightingindustries.com)

1306 DORIS AVENUE, OCEAN, NJ 07712 USA 800.462.7812 732.517.0800 FAX 732.517.0971 © 09/07