

Single lamp, low-voltage halogen recessed wall washer with nominal 4" square aperture.

TYPE: _____

JOB: _____

SPECIFIER: _____

SPECIFICATIONS

HOUSING - Precision die-formed heavy gauge aluminum with adjustable mounting bracket.

MOUNTING - Recessed in architectural ceiling.

ELECTRICAL - Integral dimmable electronic transformer. 120v primary lead, (220v, 240v, 277v available), 11.75v secondary with overload protection. External thermoprotector. Remote magnetic transformer available.

LAMP - MR-16 NFL, 50w max. supplied by others.

LABELS - UL, C-UL, Damp location

SOCKET - Precision die-formed aluminum socket plate. G4/G6 ceramic socket with high temperature, teflon coated lead wires.

LENS - Supertex borosilicate spread lens, hinged for relamping. Optional filters available for lampholder.

TRIM - Flanged or flangeless, one piece die-cast aluminum pyramidal shield.

FINISH - White powder paint housing. Aperture trim available in black and white as standard. Additional colors and RAL palette available. Consult factory for custom finishes.

APPLICATIONS

Wall washing in low to medium ceiling heights typically found in residential, commercial and retail applications. Suitable for new construction. Zero trim can be used with in solid surface ceilings such as wood, stone, metal panel or glass.

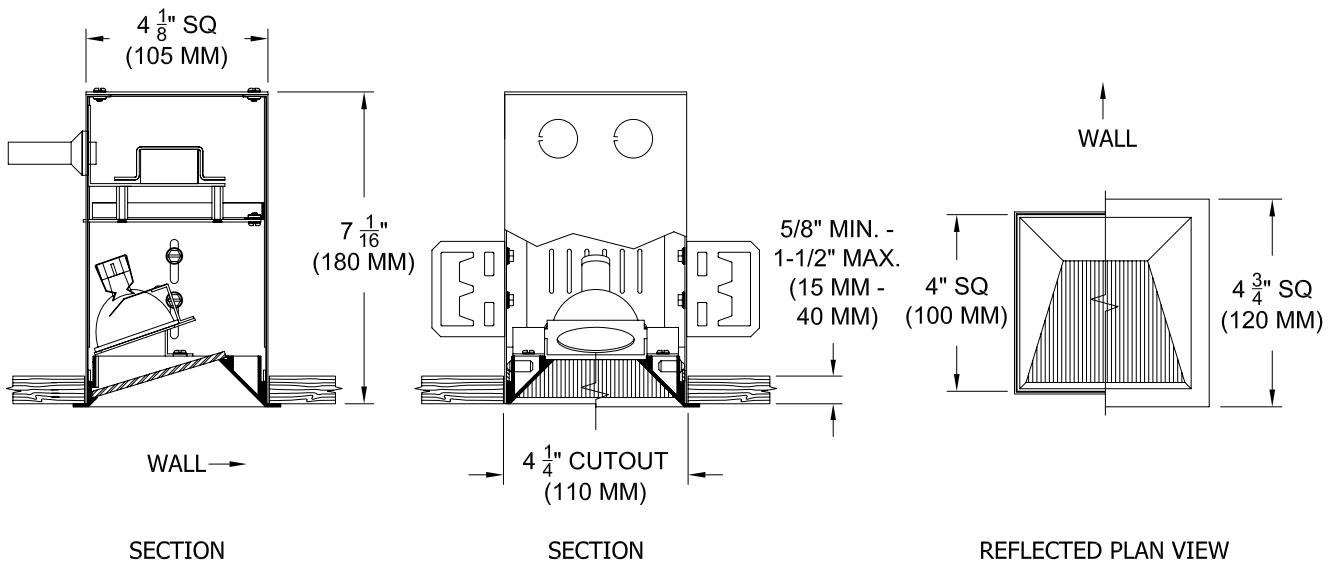

ORDERING INFORMATION

HOUSING	TRIM	TRANSFORMER	LAMP LENS	TRIM FINISH	APERTURE LENS
1240-MR16-CUH					92A
Compact Universal Housing	FT = Flanged Trim ZT = Zero Trim	EX = Electronic RX = Remote	98L = UV Filter	P14 = White BLK = Black PXX = SLI Color XXXX = RAL # CST = Custom	92A = Supertex



SPECIALTY LIGHTING INDUSTRIES, INC.

NOTE: These specifications subject to change without notice.

www.specialtylightingindustries.com

1306 DORIS AVENUE, OCEAN, NJ 07712 USA 800.462.7812 732.517.0800 FAX 732.517.0971 © 03/09