

Dual lamp, low-voltage halogen, recessed accent light with nominal 4" x 9" rectilinear aperture and optional glass diffuser.

TYPE: _____

JOB: _____

SPECIFIER: _____

SPECIFICATIONS

HOUSING - Precision die-formed heavy gauge aluminum with flangeless trim and integrated screed edge.

MOUNTING - Install from below into sheetrock ceiling.

ELECTRICAL - Integral dimmable electronic transformer. 120v primary lead, (220v, 240v, 277v available), 11.75v secondary with overload protection. External thermoprotector.

LAMP - (2) MR-16, 50w max. supplied by others.

LABELS - UL, C-UL, Damp location

SOCKET - Precision die-formed aluminum yoke with CNC machined lampholder assembly. G4/G6 ceramic socket with high temperature, teflon coated lead wires.

LENS - Clear pyrex safety lens. Optional borosilicate lenses available for lampholder and aperture.

TRIM - Flangeless, one piece die-cast aluminum pyramidal shield.

FINISH - Black powder paint housing. Aperture trim available in black and white as standard. Additional colors and RAL palette available. Consult factory for custom finishes.

APPLICATIONS

Accent and downlighting in low to medium ceiling heights typically found in residential, commercial and retail applications. Suitable for new or existing construction in sheetrock ceilings with restricted plenum depth.

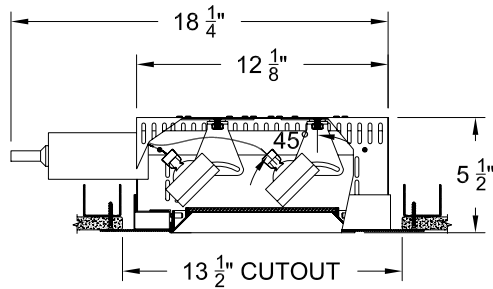

SECTION

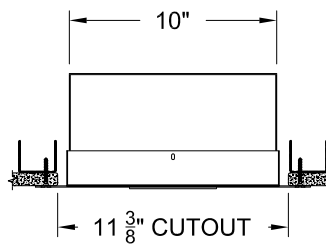

SECTION

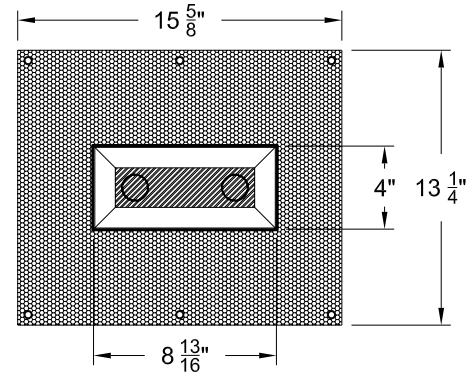

REFLECTED PLAN VIEW

ORDERING INFORMATION

HOUSING	TRIM	TRANSFORMER	LENS HOLDER	LAMP LENS	TRIM FINISH	APERTURE LENS
1009-2MR16-SPH	ZT					
Shallow Plaster Housing	ZT = Zero Trim	EX = Electronic EX2 = 2 cir. Elect. RX = Remote	CL= Conical FL = Flat IL = Indexed	90L = Clear 91L = Solite 92L = Supertex 95L = Full Prismatic 96L = Black Hexcell	P14 = White BLK = Black PXX = SLI Color XXXX = RAL # CST = Custom	Blank = None 91A = Solite 92A = Supertex 93A = Sandblasted 95A = Full Prismatic



SPECIALTY LIGHTING INDUSTRIES, INC.

NOTE: These specifications subject to change without notice.

www.specialtylightingindustries.com

1306 DORIS AVENUE, OCEAN, NJ 07712 USA 800.462.7812 732.517.0800 FAX 732.517.0971 © 03/08